



Pneumatic Tyre Roller

524H



EU Stage
IIIA / EPA
Tier 3



Technical Specifications

Machine Masses

Minimum Operating weight	11,000 kg
Max operating weight	24,000 kg

Compaction Data

Distributed load @ each tyre	2800Kg
Ground Pressure	220-420 /260-490 Kpa
Wheel track overlap	45mm
Compaction Width	2250mm
Wheel Base	3600mm
Number of Tyres	4 x front - 5 x rear

Performance and Traction

Theoretical Gradeability	40°
Front wheel Swing angle	±50
Outside Turning Radius	7500mm
1 st Speed	0 - 8km/h
2 nd Speed	0 - 20km/h
Steering Type	3- point steering
Oscillation Type	3- point oscillation

Tyres

Tyre Size	11.00 x 20 x 18Ply
-----------	--------------------

Engine

Manufacturer	Cummins USA
Model	QSB4.5 C130
Emission Regulation	ISO 14396 Tier III / Euro stage 3A
Rated Power	130HP @ 2000rpm
Max Torque	650 Nm
Cylinders	4
Type	Water cooled/Turbo

Hydraulic System

System Pressure	420 + 350 Bar
Driving Type	Fully Hydrostatic
Regulation Type	Variable Speed
Traction Type	Hyd Sync Traction
Steering Type	Hydrostatic
Parking Brake Type (drum & axle)	Fail safe wet disc
Service Brake Type	Hydrostatic

Service capacities

Diesel Tank	220 l
Hydraulic Tank	70 l
Cooling System	25 l
Engine	11 l

Features & Technical Specifications

The new generation Multipac 524H series boast many new advanced features which delivers outstanding performance along with driver comfort and unmatched reliability. Designed and engineered in Germany only to incorporate the best components to meet and excel in the harshest of working conditions. The 524H is Highly compact along with a very modern design with robust characteristics through brilliant design and structural integrity.

The following standard Features consist of the following:

- Powerful Cummins Engine - Euro stage 3A / Tier III compliant.
- 4 tyres on the Front and 5 at Rear allowing better turning circle and increase compaction.
- Single seat with slide system. The operator's seat shifts with the steering column from left to right for increased visibility and operator comfort.
- Ergonomic joystick control mounted to the operator's seat.
- Hydrostatic Drive system.
- LED work light kit.
- Electric Tilttable cabin allowing for 100% access to engine and Hydraulic system.
- Remote filters for easy fast servicing.
- Easy removeable ballast which varies from 11 – 24 tonne.
- Factory air-conditioning and heating.
- Reversing Camera.
- Front Tow hitch.
- Compact state-of-the-art design.

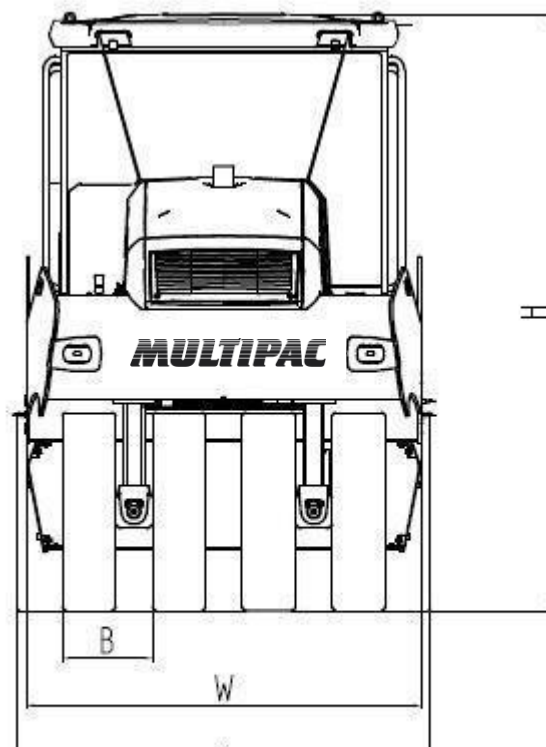
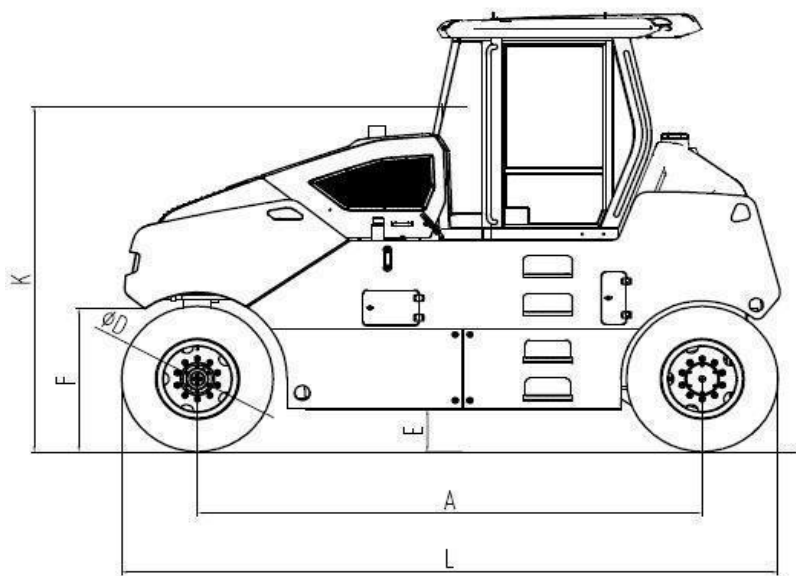

	W	C	L	E	A	H	B	F	K
524H	2150	2250	4800	290	3600	3270	490	900	2500